

RECOMMENDED FPC/FFC DIMENSIONS  
GENERAL TOLERANCE ±0.1

NOTES:

1. MATERIAL:
  - 1.1 HOUSING: THERMOPLASTIC, HIGH TEMP., UL94V-0.
  - 1.2 ACTUATOR: THERMOPLASTIC, HIGH TEMP., UL94V-0.
  - 1.3 CONTACT: COPPER ALLOY
  - 1.4 FITTING NAIL: COPPER ALLOY
2. FINISH:
  - 2.1 CONTACT:
    - 1:50u" MIN NICKEL UNDERPLATING OVERALL.
    - GOLD FLASH PLATING.
  - 2.2 FITTING NAIL:
    - 50u"MIN NICKEL UNDERPLATING OVERALL.
    - 100u"MIN MATT TIN PLATING ON SOLDER TAILS(LEAD FREE).
3. REFLOW SOLDER CAPABLE TO 260°C PER ACES SPEC.
4. SPEC. PLS. REFER TO PS-51625-XXXXX-XXX
5. PACKAGE PLS. REFER TO 51625-XXXXX-00-TRP
6. PART NUMBER

51647-XXX X X-VXX		XXX	HOUSING MATERIAL&COLOR	ACTUATOR MATERIAL&COLOR
PACKING	NO OF CKT	001	HF & BLACK	HF & WHITE
0: TAPE & REEL			PLATING	
			1: G/F PLATING(LEAD FREE)	

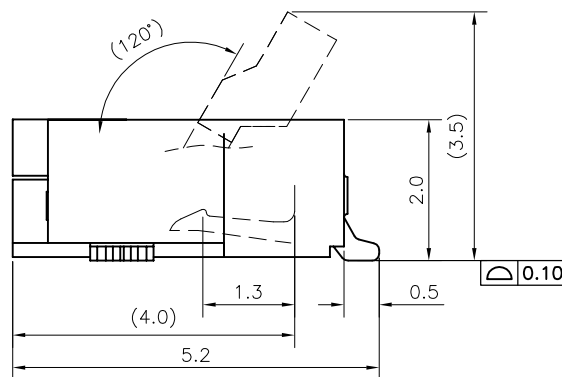
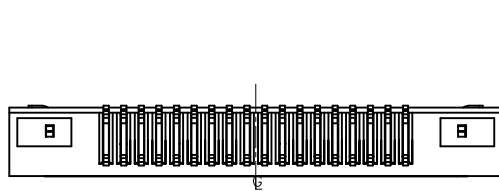
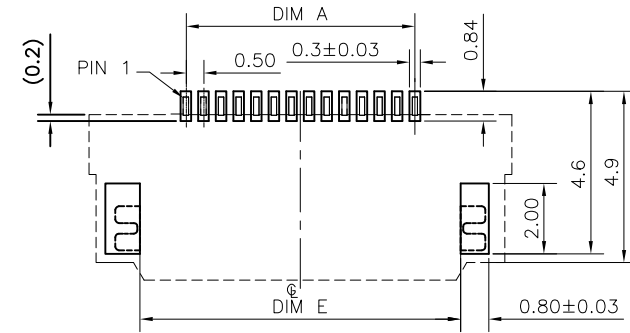
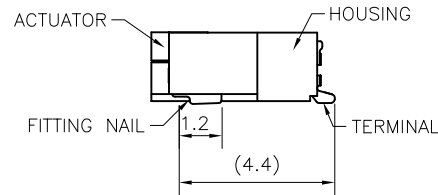
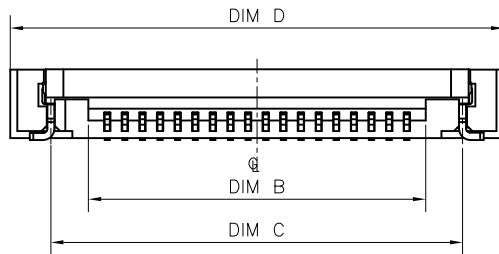

SCALE 6:1

CKT	DIM A	DIM B	DIM C	DIM D	DIM E	DIM F
10	4.50	5.57	7.70	10.0	7.1	9.6

<b>QUALITY SYMBOLS</b> MAJOR Ⓞ CRITICAL Ⓞ <b>GENERAL TOLERANCES (UNLESS SPECIFIED)</b> X. ±0.5 .X ±0.25 .XX ±0.15 .XXX ±0.1 ANGLES ±2°	DRAWN BY GUOFEI	DATE '21/08/17	
	CHECKED BY BRAVE	DATE '21/08/17	
	APPROVED BY BRAVE	DATE '21/08/17	
	UNITS mm	SIZE A4	
SCALE 3:1	SHEET NO. 1 OF 1	REV A	PART NO. SEE NOTES